

SEIT 1928

KONDENSATORMIKROFONE
FÜR STUDIO - UND MESSTECHNIK

MICROTECH GEFELL



DIFFUSE FIELD MICROPHONE

- extreme dynamic range
- low noise floor
- large membrane capsule
- advanced circuit design
- transformerless output
- high sensitivity
- compact design
- price right

STUDIO CONDENSER MICROPHONE

M 960 ○

STUDIO CONDENSER MICROPHONE M 960

High output level and low noise

M 960 with omni-directional pattern **diffuse field**

The M 960 studio condenser microphone combines well-proven large diaphragm capsule technology with the latest in semiconductor circuit topology.

It is specifically designed to meet the needs of professional and semi-professional users who demand the highest performance.

The M 960 is ideally suited for miking applications in broadcast and sound studios.

Applications include recordings outside the diffuse field distance during choir or orchestra performances, e.g. in concert halls, churches and theatres.

The pick-up pattern of the microphone is axial.

The condenser capsule is designed for a diffuse field. It exhibits a presence boost in the 4 to 12 kHz range.

The electronic impedance converter uses a newly perfected circuit topology. This design reduces the noise floor to an extremely low level while also raising the maximum output capability. As a result, this microphone has a clean, distortion-free sound over an extremely wide dynamic range.

The M 960 is either mounted by means of the microphone stand holder MH 93.1, which is included or the optional swivel mount MH 93. If necessary the microphone stand holder can be exchanged for the elastic suspension EH 93 to further attenuate noise (in extreme situations).

The M 960 connects to the microphone cable with a standard 3-pin XLR plug. Powering must be provided by an external 48 V phantom supply according to DIN EN 61938 and IEC 1938.

The microphone is finished in dark bronze.

M 960 with microphone holder MH 93.1



ACCESSORIES, optional

| | |
|---------------------------------|-------|
| Windscreen, anthracite | W 96 |
| Elastic suspension, dark bronze | EH 93 |
| Microphone holder, dark bronze | MH 93 |
| Power supply | N 200 |
| Microphone cable | C 70 |

Order-No. 202412

Order-No. 202328

Order-No. 202326

Order-No. 202101

Order-No. 202212

TECHNICAL SPECIFICATIONS

| CE Certificate | | M 960 | |
|---|---------------------------|---|----------|
| Polar pattern | | Omni-directional for diffuse field | |
| Acoustic operating principle | | Pressure transducer | |
| Frequency range, free field | | 20...20000 | Hz |
| Sensitivity at 1 kHz | | 16 | mV/Pa |
| Output impedance | | 100 | Ω |
| Equivalent loudness level due to inherent noise | CCIR 468-4 | 19 | dB |
| | DIN EN 60 651 | 9 | dB-A |
| Signal-to-noise ratio (re at 1 Pa at 1 kHz) | CCIR-weighted | 75 | dB |
| | A-weighted | 85 | dB |
| Max. SPL for THD < 0,5% | | 145 | dB |
| Max. Output level | $R_L = 1\text{ k}\Omega$ | 17 | dBu |
| | $R_L = 10\text{ k}\Omega$ | 18 | dBu |
| Dynamic range of electronics | | 135 | dB |
| Current consumption (P 48, DIN 45596, IEC 268-15) | | 3,6 | mA |
| Output connector | | 3-pin XLR connector gold-plated contacts | |
| Weight without MH 93.1 | | 220 | g |
| Dimensions (L x \varnothing) | | 90 x 45 | mm |
| Finish | | Dark bronze | |

DELIVERY

The microphone is delivered in a wooden case with microphone stand holder MH 93.1 L x B x H 180 x 106 x 78 mm

Order-No. 211171

Ordering example:



POLAR PATTERNS

FREQUENCY RESPONSE



diffuse field

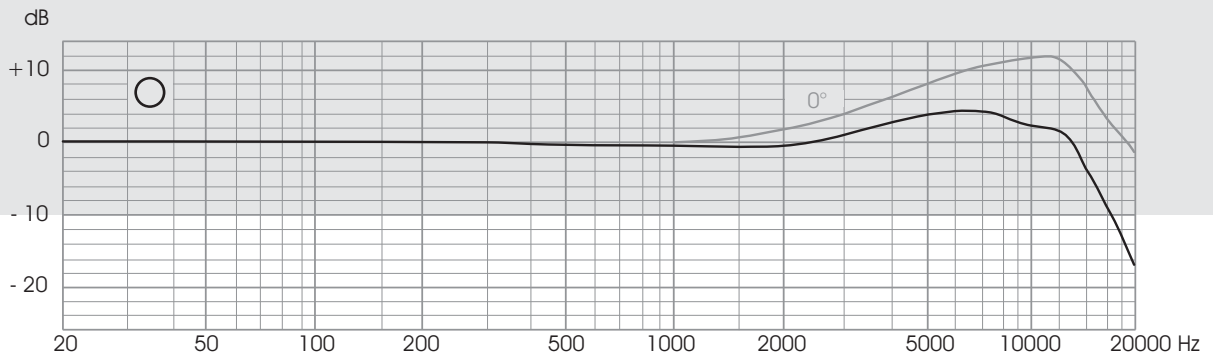

free field

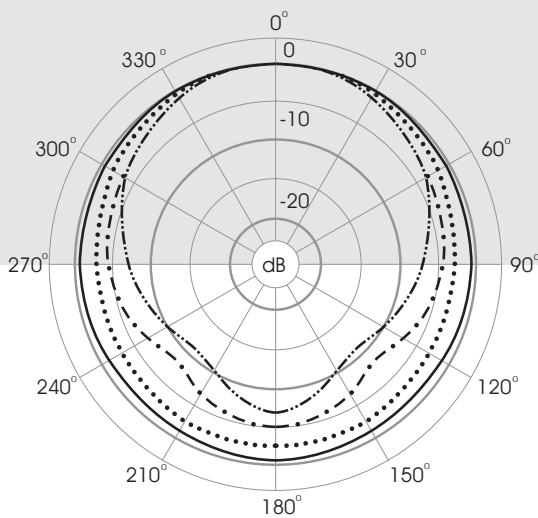

— 1 kHz
 2 kHz
 - - - 4 kHz
 - · - · 6 kHz

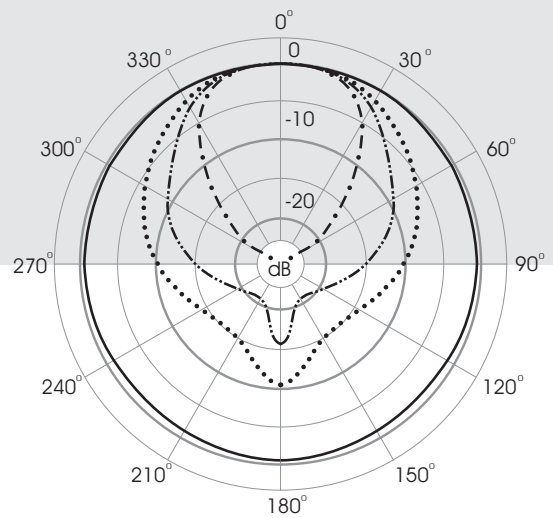

— 1 kHz
 8 kHz
 - - - 10 kHz
 - · - · 16 kHz

M 960