



# Audio Engineering Society

# Convention Paper

Presented at the 130th Convention  
2011 May 13–16 London, UK

*The papers at this Convention have been selected on the basis of a submitted abstract and extended precis that have been peer reviewed by at least two qualified anonymous reviewers. This convention paper has been reproduced from the author's advance manuscript, without editing, corrections, or consideration by the Review Board. The AES takes no responsibility for the contents. Additional papers may be obtained by sending request and remittance to Audio Engineering Society, 60 East 42<sup>nd</sup> Street, New York, New York 10165-2520, USA; also see [www.aes.org](http://www.aes.org). All rights reserved. Reproduction of this paper, or any portion thereof, is not permitted without direct permission from the Journal of the Audio Engineering Society.*

## Digital Microphones – What's it all about?

John Willett

Circle Sound Services, Oxfordshire, UK  
[john@circlesound.net](mailto:john@circlesound.net)

### ABSTRACT

It's now ten years since the first AES42 specification was published (AES42-2001) and the first AES42 compliant digital microphone came to the market. So this seems an opportune moment to look at AES42 digital microphones, their history, what they offer, the current market situation and what the future may hold.

### 1. INTRODUCTION

#### 1.1. The Beginnings

At the end of the last century a few manufacturers started to produce digital microphones; I suppose the most notable was the MCD 100 from Beyerdynamic which was really the first digital studio microphone.

As there was no standard at the time, all these microphones used a different architecture.

It quickly became obvious that this would be unsatisfactory in the long run; so, at the European AES Convention in 1997, the microphone manufacturers were urged to get together and work out a common AES standard for digital microphones. This they did, with other interested parties involved as well. This resulted in the first version of AES42, AES42-2001, being published in 2001. This was later updated in 2006 to AES42-2006 and a further refinement, AES42-2010 was published in March 2011.

#### 1.2. Intentions

It is not my intention to go into lots of technical details in this paper, as much has already been written on the subject and I don't intend to repeat it all. I would, however, like to draw your attention to the Papers by Stephan Peus that can be downloaded from the Neumann website, various papers downloadable from the Schoeps website and the "White Paper: Digital Microphones and AES42" downloadable from [www.hauptmikrofon.de/AES42](http://www.hauptmikrofon.de/AES42).

What I would like to do, is to talk about how AES42 microphones are developing, the variety of microphones available on the market and the ancillary equipment available to compliment them.

I will also talk about the advantages of digital microphones over analogue and my own experience in using them in anger – my first all-digital recording session was at the end of 2006. I will also look at the possibilities for the future.

## 2. WHY DIGITAL MICROPHONES?

### 2.1. What is a Digital Microphone?

In the literal sense, I suppose, a “digital microphone” is a microphone that directly converts air movements into digits. Well, such a device does not yet exist (at least, as far as I know).

A “digital microphone” as far as we are concerned today is one that has the analogue to digital converter as part of the microphone itself and located as soon as possible after the diaphragm.

The microphone outputs a digital signal according to the AES42 specifications – this is basically a standard AES3 signal, but AES42 includes additional data in both directions, plus phantom power. This phantom power is not the same as analogue microphones – the phantom power for digital microphones is 10V at up to 250mA. This power was a compromise between what the microphone manufacturers asked for and what the console manufacturers wanted. After all, for example, twenty-four digital microphones all drawing 250mA means that the console manufacturers would have to beef up the power supply – so they met half-way and both were satisfied (if not actually happy).

### 2.2. What does an AES42 microphone offer?

#### 2.2.1. The analogue chain

Let’s start by looking at a normal analogue condenser microphone and how we treat the analogue signal:-

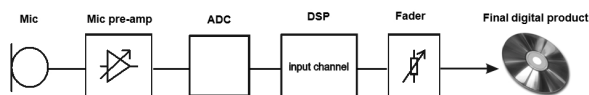

Figure 1 - Analogue microphone chain

The microphone is connected by a cable (which can be very long) to a mic. pre-amplifier. This amplifies the signal to line level. This is eventually sent on to the Analogue to Digital Converter (ADC); either directly, or via an analogue mixing console. Now in the digital domain the signal can be manipulated as required eventually ending up as the final digital product.

So, what’s the problem with this?

Let’s assume a microphone with a 130dB dynamic range:

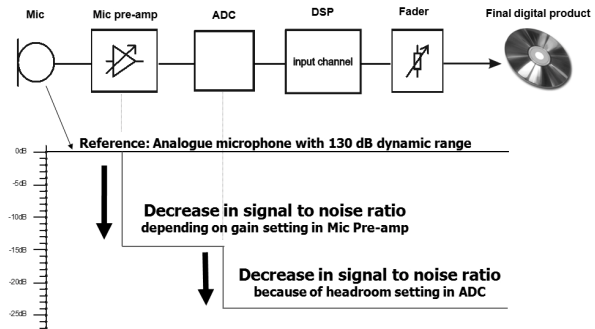

Figure 2 - Decrease in s/n ratio

Firstly, you can never have a perfect signal chain as analogue circuits add noise – OK, it’s small, but each extra stage adds its bit. Also, you have to raise the signal level of the microphone without raising it so much that the signal distorts, so you have to back-off a bit.

The same with the ADC, you must keep the signal under 0dBFS or the signal will clip – so you set the level to allow sufficient headroom for peaks to prevent this happening – the EBU norm is to use -18dBFS as the 0VU point.

As you can see from Figure 2 above, these can result in a decrease in signal-to-noise of about 25dB

#### 2.2.2. Making it better

So – how does an AES42 microphone improve this?

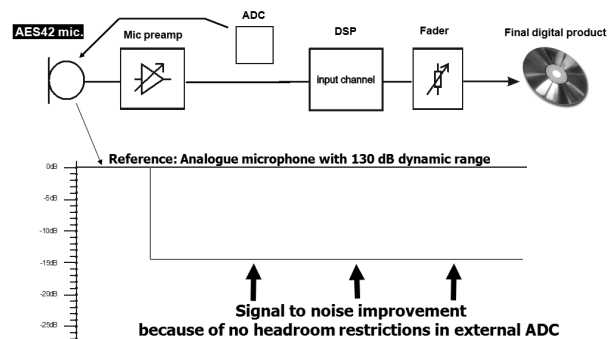

Figure 3 - ADC in the microphone

By having an ADC in the microphone itself, specifically designed for the capsule, we remove need to “back-off” and so get an ideal translation from analogue to digital.

So we get back the first section of the reduced headroom.

Next we remove the external microphone pre-amplifier from the chain – in fact we can also remove the line driver amplifier from the microphone as well; leaving the absolute minimum of analogue components in the microphone itself – basically the capsule, the FET and not much more.

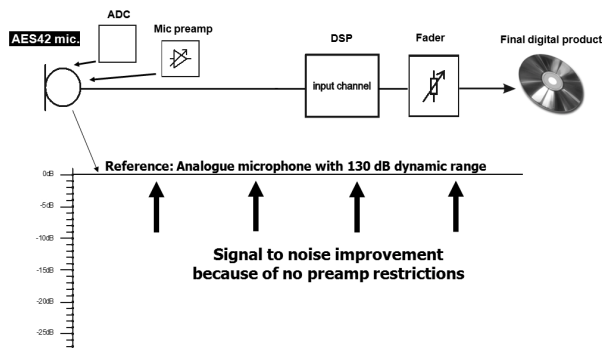

Figure 4- No external mic. pre-amplifier

So now we have available the full dynamic range of the microphone and the sound of the capsule not coloured by analogue circuitry.

### 2.2.3. Analogue bottlenecks

Let’s look again at the analogue microphone chain:

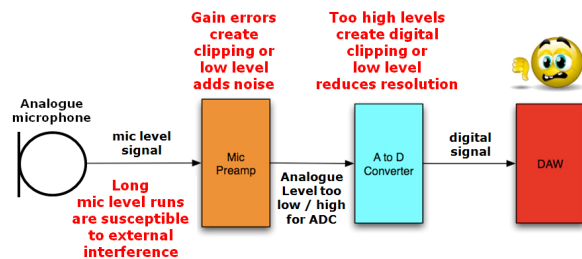

Figure 5- Analogue bottlenecks

First the microphone is connected by cable to the pre-amplifier. This is susceptible to picking up noise and interference.

This cable is connected to the pre-amplifier (mixer input) where the level is increased, adding noise in another analogue circuit in addition to the noise added by having to allow for headroom, or the risk of distortion if too high – also another place where RF interference can enter the chain. On to the ADC with the risk of clipping and having to back-off to allow headroom.

The result – reduced dynamic range at best and distorted and clipped audio with external interference at the worst.

By having the ADC inside the microphone all this is removed, instantly making the signal immune from external RF interference along the chain as the signal is in digits from the start.

### 2.2.4. The AES42 signal

The AES42 signal carries data in both directions.

At the heart is the 24-bit AES3 audio stream. Piggy-backed on top of this is microphone data like make, model number and serial number.

Going the other way is 10V phantom power with a maximum current draw of 250mA – pulses can peak 2V above this for control signals. Also going this way is remote-control data for adjustments in the microphone, switching the red and blue lights and for adjusting the polar-pattern of switchable microphones.

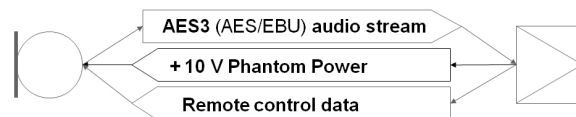

Figure 6- The AES42 signal

It is also possible to update the firmware in the microphones via the controller attached to a computer.

### 2.2.5. So – why digital microphones?

The AES42 digital microphone removes the analogue noise, RF interference and the deterioration of the audio signal as it travels along the analogue audio chain and replaces it with clean audio, immune from external interference, digitised as close to the microphone capsule as possible.

### 3. THE AES42 MICROPHONE

#### 3.1. Mode-1 / Mode-2

AES42 allows for two different modes of operation:

**Mode-1** is AES42 in its basic form. Each microphone is free-running from its own internal clock – so, if you want to use several AES42 microphones together, they will have to go through a sample-rate converter to clock them.

**Mode-2** allows the microphones to be clocked from the receiving equipment – the clock signal is sent to the microphones as part of the data stream. Advantages include: no SRC and a constant phase relation (close to 0°) between different microphones independent of cable length or other influences. Mode-2 devices can also be run as Mode-1 when being used in a system that also contains microphones that work Mode-1 only.

#### 3.2. What else is in there?

It’s easiest to see this visually – this is a channel strip from the Neumann RCS software, but the data is inherent in the AES42 specs. for all microphones:

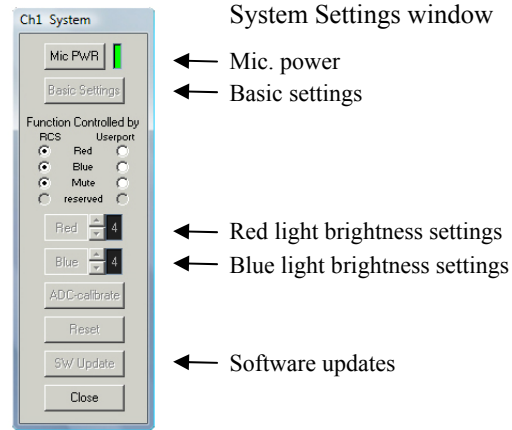
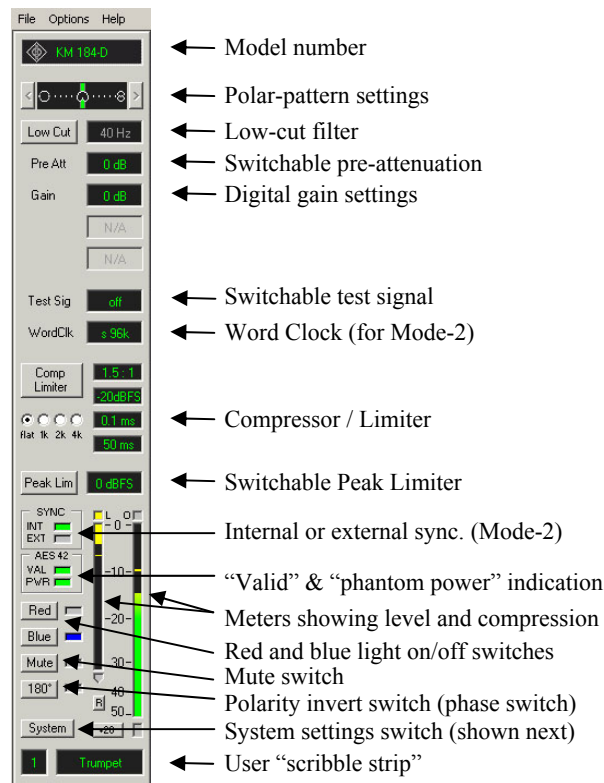

Figure 7- RCS software displays

You can see from the figures above that there is a lot in there.

The basic AES42 settings are:

- Polar-pattern (15 steps – omni to fig-8)
- Low-cut filter (none, 40Hz, 80Hz, 120Hz)
- Pre-attenuation (none, 6dB, 12dB, 18dB)
- Gain (unity to +63dB in 1dB steps)
- Peak limiter (on/off)
- Mute
- Mode-2 synchronisation

Although signal gain is not really necessary as it does not improve the signal quality – it is useful to have as it enables easier monitoring while recording.

AES42 also allow extra settings, some of which are:

- Sample frequencies (8 possible: 44.1, 48, 88.2, 96, 176.4, 192, 352.8 or 384kHz)
- MS / XY selection
- Stereo / mono selection
- Control of two lights
- Brightness setting for the lights (16 steps)
- Test signals
- Compressor / limiter with selectable ratio, attack and release
- Microphone identification and status flags



- Equaliser (255 manufacturer-specific settings or “no equaliser”)
- Polarity switch (phase reverse) 180°
- Etc.

The new AES42-2010 standard, just published, adds the AES42 system-command set to enable storage and recall of user settings in the microphone itself. It also adds a new feature: Since the original upload times were not acceptable for a firmware update using the AES42 interface the bit rate can now be changed. This optional higher bit rate, called Fast-DPP mode, can be used to transmit DPP commands or firmware update data. In addition an optional periodic transmission control feature is introduced to allow manufacturer-specific command sets for remote control of microphone features.

The AES42 specification allows for a lot of flexibility – so although the cost of an AES42 microphone may look expensive initially; you are not only doing away with a mic. pre-amp., you get all this extra stuff as well – so it ends up being not so expensive at all.

#### 4. IN USE

When I first heard about digital microphones I was not initially that impressed – OK, a good idea, but not that special. But when I really started to look into AES42 in detail, the advantages became very clear. The two main things that got me were the increase in dynamic range I mentioned earlier and the built-in limiter to silently prevent clipping.

I was hooked, I purchased my first set of AES42 microphones at the end of 2006 – Neumann KM-D in my case – and used them on piano recital sessions in The Menuhin Hall, starting in December '06.

The first “problem” I had was that I was recording the piano from a distance of about two metres. The KM 183-D microphones I had were diffuse-field omni (the KK 131 nearfield omni was not available then) and the sound was obviously too bright due to the diffuse field frequency response curve. Looking at the published curve and polar-pattern I could see that the microphone had a flat response at about 90° so, after experimenting with various angles, I positioned the microphones vertically which gave the best sound that the client was happy with.



Figure 8- Richard Meyrick, Blüthner Piano and KM 183-D microphones

The microphones were about head-reference distance apart, at ear height and about two metres from the piano (*The MKH 20s in the picture above were the back-up system*).

The Menuhin Hall is a great recording venue, and I set up the equipment in the Green Room. This is close to, but well isolated from, the stage so there is no sound leakage between the two.



Figure 9- Set-up in the Green Room

The two KM-D microphones were fed to the Neumann DMI-2 interface, the AES3 output was split – one going to a Fostex FR-2 recorder at 24/88.2 and the other went through an Audio Design Probox10 sample-rate converter and backed-up to DAT.

Belt and braces: I ran a totally separate back-up system of MKH 20 analogue microphones into a second FR-2 via an Audio Design DMA-2; the FR-2s were just being used as bit-buckets.

I was running the RCS software on the laptop and monitoring levels there – I did set a +25dB gain so I had a sensible level to monitor with, still leaving plenty of headroom. The peak limiter was actually not needed at all.

The sessions went very well and very smoothly. I was contracted to record four solo piano recital CDs with Richard Meyrick, pianist. This was for the Man Group as part of the PianoMan project where Richard does Master Classes in schools across the country.

In use the digital microphones were just as easy to use as analogue microphones – though they did keep giving me “heart failure”. Every time we went to play back a take to check it, it initially sounded like nothing was recorded. There was none of that very low level background noise you get with an analogue signal chain. You don't really notice this low level noise in practice, but your brain must hear it, because when it was not there I kept feeling the recording had failed – until I heard the take numbers being called out and the music starting. So, yes, the better dynamic range really is noticeable.

For the four CDs we did several sessions over a period of about fifteen months. We had to have gaps between sessions so the pianist could learn the next batch of pieces. Everyone was delighted with the final outcome.

Since these sessions I have used the KM 183-D in my Jecklin and Schneider Disks and have also purchased the KK 131 nearfield omni heads which I used for my last piano recording sessions at Waterloo in London (I don't have to have these vertical).

I also added to my digital kit with the Sennheiser MZD 8000 module. This is to the stereo spec. in AES42 and will take two of the MKH 8000 series heads (although they can also be used singly). The big advantage of this is, because it is a single module, both channels are on the same clock and a stereo pair can be connected to a single AES3 input via a simple powering box (I'll say more about this later) and you don't need a large external interface. I have both a pair of cardioids for an ORTF set-up and a pair of omnis for piano recording. I did have to buy a couple of remote cables

and cut them to make my own Y-cable to do this as the official cable was not suitable. This set-up works very well in practice (though there is a 3dB penalty in using the MZD 8000 in stereo mode rather than mono).



*Figure 10 – My Sennheiser MZD 8000 set-up with custom Y-cable and MKH 8020 stereoset*

I have upgraded my recording system over the last few years and my main recorder is now the Nagra VI. Unfortunately, unlike the Sound Devices 788T, it cannot take in AES42 microphones direct; so I have recently purchased two of the new Neumann DMI-2Portable interfaces to enable four channels of AES42 recording through the two AES3 inputs of the Nagra VI. The recorder happily supplies the DC power to power the two units and they are both clocked to the very accurate word clock of the Nagra VI.

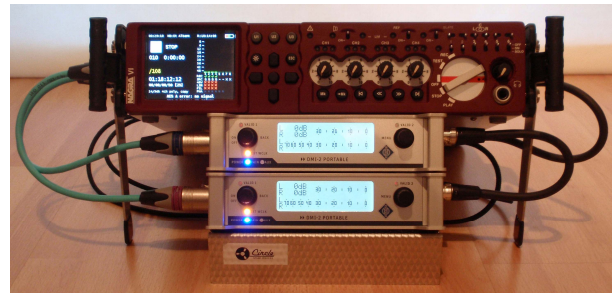

*Figure 11 - Current rig: Nagra VI with a pair of Neumann DMI-2Portable for four AES42 microphones powered and clocked from the recorder*

Because the Nagra does not have sample-rate converters, I have designed the system around Mode-2 microphones; it does mean, unfortunately, that I cannot use Mode-1 microphones in the system.



Although my own use is mostly with minimalistic mic. technique in a live acoustic, AES42 microphones are also ideal for large scale recordings. I attended a session at Abbey Road #1 a couple of years ago for a recording of the LSO where every microphone was digital. Over 30 AES42 microphones were used. These were connected to RME DMC 842 interfaces which were fed via MADI to a computer and the results recorded on Sequoia.



Figure 12 - RME interfaces at Abbey Road with a Neumann DMI-8 on the top

AES42 uses standard balanced XLR microphone cables up to about 100-metres. Using proper AES cable can double this. I have also seen adaptors which enable you to run AES42 along a dedicated Ethernet cable – I tried it, it certainly works.

## 5. WHAT’S AVAILABLE?

### 5.1. Microphones

Almost immediately after the first AES42 spec. was published, Neumann released the very first AES42 compliant digital microphone under the “Solution D” banner. This was the D-01. As this was the very first AES42 microphone, Neumann went to town on the design and incorporated into it almost every possible option. It is a large diaphragm Mode-2 switchable-pattern microphone and Neumann designed a brand new transducer for this new microphone.



Figure 13 - Neumann D-01

Second on the scene was Schoeps. They decided to go to the other extreme and to produce a simple Mode-1 module for their Collette series. This was a canny way to go, as a single module with interchangeable heads means that this single unit makes quite a lot of microphones; there is even a boundary microphone option.



Figure 14 - Schoeps CMD 2 with a selection of capsules

This means that existing Schoeps users can go AES42 by getting the CMD 2 and use their existing Collette series microphone capsules. The CMD 2 will also work with all the other accessories in the series – so one product gives you a complete series of AES42 digital microphones. There are actually 21 capsules and over 100 accessories in the series!

In 2006 Neumann introduced their second AES42 microphone. Taking the same sort of route as Schoeps they introduced the KM-D module. However, instead of using existing KM 100 series heads, Neumann decided to produce a complete new series. Launched with the three basic: diffuse field omni, cardioid and super-cardioid heads, they have since extended the series with: nearfield omni, sub-cardioid, figure-8, ball-head diffuse field omni, etc., so there are now eight capsules in the series. There is even a KM-A analogue module in the series so the same capsules can be used analogue or digital. Neumann have since added large diaphragm condensers, vocal microphones and gun microphones to their AES42 cupboard. All Neumann AES42 microphones are Mode-2.



Figure 15 - Neumann KM-D

Sennheiser were latecomers to AES42. They, again, went down the module route and produced the MZD 8000 to accompany their MKH 8000 series. Sennheiser had to take a slightly different route as MKH microphones are RF condenser microphones and the heads are actually complete microphones with a normal microphone output level. Again a Mode-2 device, the MZD 8000 is unique at the moment in that it is a mono/stereo module. You can screw an MKH 8000 series head directly onto the MZD to make a single AES42 microphone, or, via a Y-cable you can connect two heads as a stereo pair (see Figure 10). Although there is a 3dB noise penalty in this stereo mode, it has the advantage of being able to be connected to an AES3 or S-PDIF digital input by using a simple connection kit

(both Neumann and Schoeps do these). Sennheiser have omni, cardioid, super-cardioid, short gun and long gun heads available now. Sadly, no figure-8 or sub-cardioid heads are available yet and the Y-cable I had to make myself (though all the 8000 series remote cables and extension tubes are already stereo enabled).



Figure 16 - Sennheiser MZD 8000

Schoeps then set the cat among the pigeons with their SuperCMIT gun microphone. This is not just any run-of-the-mill gun microphone – Schoeps took advantage of AES42 to include digital processing inside the microphone. They incorporated an additional rear-facing cardioid transducer inside the microphone in addition to the normal gun capsule. In its simplest form the SuperCMIT is a standard AES42 short gun microphone. But switch in the processor and the rear cardioid comes into play – polarity reversed, this capsule helps to make the microphone more directional and, uniquely, reducing the rear out-of-phase lobe. A second setting has even more processing and virtually eliminates the rear lobe completely, but with some artefacts so this option has to be used carefully.



Figure 17 - Schoeps SuperCMIT



The one thing that really excites me about the SuperCMIT is not just the microphone itself, which is certainly being well received, but the possibilities for the future with a DSP included inside the microphone.

## 5.2. Interfaces

The simplest interface is a simple connection kit. These enable a single AES42 microphone to be connected to a standard AES3 or S-PDIF input. Both Neumann and Schoeps do these: Neumann do an AES3 and S-PDIF connection kit which are supplied complete with a mains adaptor. There is also an optional battery box for these. They also do a “video” AES3 kit which is powered via a Hirose connector from the recorder – I have one of these – unfortunately it is a “special order” item rather than a standard product. Schoeps also do a power box, the PSD 2U, which is DC powered and supplied complete with a mains unit. There is a choice of co-axial or Hirose connector for the DC (personally I would choose the Hirose as it’s lockable).



Figure 18 - Neumann & Schoeps connection kits

Neumann do three full digital interfaces: the DMI-2 is a two-channel mains-powered interface, the new DMI-2Portable is a smaller DC-powered interface for mobile use (see Figure 11) and the DMI-8 is an 8-way interface (see Figure 12). All these are for Mode-2 microphones only and can be clocked together for multi-mic. systems.

RME do the DMC 842, an 8-way interface that can take both Mode-1 and Mode-2 microphones. This is in the same style as their “Mictacy” and both can be used together if a mixed analogue/digital system is required.



Figure 19 - RME DMC 842

Marian do the TRACE AES 42-4 computer interface card, Lake People do the DAC C462 with both AES3 and analogue outputs, StageTec do a Mode-1 input card for their Nexus system, Digigram do AES42 PCI and PCIe computer cards, DigiCo are now doing AES42 inputs for their mixers and I suspect others are also working on AES42 inputs.

The Sound Devices 788T is a portable recorder with AES42 inputs. With built-in sample-rate converters, the 788T can take both Mode-1 and Mode-2 microphones. AETA have recently announced the 4MinX4 recorder with AES42 inputs.



Figure 20 - Sound Devices 788T

## 6. THE FUTURE

What does the future hold? Certainly things have progressed in the last ten years, from the lonely Neumann D-01 at the start, to a choice of about 40 microphones from three major manufacturers today.

What about other microphone manufacturers?

Microtech Gefell have been producing an AES42 measurement microphone – the MV 230 – for several years now (this takes a selection of Gefell’s screw-on measurement capsules).

They have the technology, will they start producing AES42 recording microphones? I certainly hope so.



Figure 21 - Gefell MV 230

I was excited recently when DPA announced their new Reference Standard series with a choice of modules and interchangeable heads. Now they do an interchangeable capsule series it's only one more step to produce an AES42 module to make the whole series digital. I am quite sure that DPA could be adding an AES42 module to their range in the future. Their new Reference Standard series is certainly perfect for it and, personally, I certainly hope they do it.



Figure 22 - DPA Reference Standard series

Other manufacturers of high quality microphones, like MBHO and Beyerdynamic in Germany, certainly make microphones that would benefit from an AES42 module. As I said earlier, one AES42 module makes a whole range of microphones in one fell swoop.

Maybe some manufacturers that have microphone technology without digital technology could collaborate and produce the core of an AES42 module between them – at least the main circuit could be common, with the same basic circuit being used in the different housings and capsule connection threads of each manufacturer. Maybe that's just me being hopeful – but I would like to see more manufacturers producing AES42 microphones and extending the choice.

But coming back to the Schoeps SuperCMIT – the inclusion of DSP processing within the microphone certainly opens the door for more new and exciting microphones in the future, especially with the additional control protocol in AES42-2010.

## 7. CONCLUSIONS

AES42 microphones, with the digital conversion as close to the capsule as possible, give the highest possible signal quality that cannot be degraded by the interferences and losses that analogue signals are so prone to. Having used AES42 microphones myself for five years now I am delighted that I invested, and am continuing to invest, in this technology and I am extremely happy with the results I am getting.

## 8. AES42 EQUIPMENT

### 8.1. Microphones

#### Neumann

D-01	Large diaphragm switchable-pattern
KM-D series	
KK 183	diffuse field omni
KK 184	cardioid
KK 185	super-cardioid
KK 131	nearfield (flat) omni
KK 133	diffuse field omni with ball
KK 143	wide cardioid (sub-cardioid)
KK 145	cardioid with bass roll-off
KK 120	figure-8
TLM 103-D	Large diaphragm cardioid
KMS 104-D	Vocal cardioid
KMS 105-D	Vocal super-cardioid
KMR 81-D	Short gun
KMR 82-D	Long gun (coming soon)

#### Schoeps

Collette series – CMD 2 with:	
MK 2	nearfield omni (flat)
MK 2H	omni with a mild HF lift
MK 2S	omni with a slight HF lift
MK 3	diffuse field omni
MK 21	wide-cardioid
MK 21H	wide-cardioid with a mild HF lift
MK 22	open cardioid
MK 4	cardioid
MK 4V	cardioid (vertical, side fire)
MK 41	super-cardioid
MK 41V	super-cardioid (vertical, side-fire)
MK 8	figure-8
MK 5	passive switchable, omni / cardioid
BLM 3	hemispherical boundary
BLM	boundary adaptor for MK capsules
Plus various speech-optimised MK capsule versions	

**Schoeps (continued)**

SuperCMIT gun microphone with DSP

**Sennheiser**

MKH 8000 series – MZD 8000 with:

MKH 8020 omni  
 MKH 8040 cardioid  
 MKH 8050 super-cardioid  
 MKH 8060 short gun  
 MKH 8070 long gun (rifle)

MZD 8000 + Y-cable with:

MKH 8020 stereoset 2 x omni  
 MKH 8040 stereoset 2 x cardioid

MZD 8000 + XLR-5F adaptor cable with:

MKH 800 TWIN infinitely variable pattern

**Microtech Gefell**

MV 230 omni measurement microphone

**8.2. Interfaces****DigiCo**

AES42 input card for DigiCo consoles

**Digigram**

VX222HR-Mic 1-mic (mono/stereo), Mode-1, SRC  
 VX222e-Mic as above but PCIexpress

**Innovason**

Mode-2 by controlling Neumann DMI-8 via Ethernet

**Lake People**

DAC C462 1-mic (mono/stereo)

**Marian**

TRACE AES 42-4 4-mics PCI card, Mode-1 & Mode-2

**Microtech Gefell**

USB interface – 1-mic (mono/stereo), Mode-1

**Neumann**

DMI-2 2-mics, Mode-2  
 DMI-2Portable 2-mics, DC powered, Mode-2  
 DMI-8 8-mics, Mode-2 \*  
 AES connection kit 1-mic (mono/stereo), Mode-1  
 S-PDIF connection kit 1-mic (mono/stereo), Mode-1

**RME**

DMC 842 8-mics, Mode-1 & Mode-2 \*

**Schoeps**

PSD 2U/Hirose 1-mic (mono/stereo), Mode-1  
 PSD 2U/co-axial 1-mic (mono/stereo), Mode-1

**StageTec**

XER-M Mode-1 input card for NEXUS, SRC

\* Connectivity:

The DMI-8 can connect via EtherSound or ADAT.

The DMC 842 can connect via MADI, EtherSound or USB.

**9. ACKNOWLEDGEMENTS**

Thanks to Stephan Peus (Neumann) and Helmut Wittek (Schoeps) for information and help in preparing this presentation.

**10. REFERENCES**

White Paper: Digital Microphones and AES42 from [www.hauptmikrofon.de](http://www.hauptmikrofon.de)

AES42-2010

Various PowerPoint presentations and papers from Neumann, Schoeps and Sennheiser.